

velo

TABLE OF CONTENTS

INTRODUCTION

Important Information.....	2
Required of Tools & Supplies.....	3
P-Series Assembly Overview.....	4

PRE-ASSEMBLY

Frame and Fork Preparation.....	5-6
Fork Installation.....	7

ASSEMBLING THE P-SERIES

Brake Housing Routing.....	8-9
Electric Cable Routing.....	10-11
Mechanical Cable Routing.....	12-13

Top Tube Cable/Hose Guide Installation.....	14
Top Tube SmartPak Installation.....	15
Seatpost Assembly	16-17
Seatpost Cutting Instructions.....	18

Seatpost Di2 Battery Installation.....	19
Tire Clearance.....	20
Aero Through-Axle Wheel Installation.....	21-22

OTHER

Compatible Parts and Hardware.....	23
------------------------------------	----

IMPORTANT INFORMATION

This manual is intended to guide official Cervélo retailers, through the assembly and adjustment of the Cervélo P-Series. This manual outlines the process and procedure associated with the installation of Cervélo components, as well as the routing of shifting and braking control lines only. Proprietary parts referenced in this manual are available only through Cervélo Cycles Inc. directly.

Failure to use the specified parts and follow these assembly instructions may result in loss of control while riding, leading to serious injury. This manual is not intended to replace the assembly and service instruction provided by third-party component manufactures, and assumes that the assembler is a trained, professional bicycle mechanic. See <https://www.probma.org/>







NOTE: Cervélo strongly recommends that all assembly and adjustment procedures be performed by an authorized Cervélo retailer. If you are a Cervélo P-Series consumer/purchaser reading this manual we suggest that before attempting to undertake any of the procedures in this manual that you consult your authorized Cervélo retailer, or visit us at www.cervelo.com/support



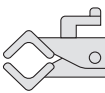



LIST OF TOOLS & SUPPLIES

This manual outlines a number of procedures for making optional adjustments to the P-Series which differ from the way the bicycle is originally sold by Cervélo. The following tools and parts listed are required for these adjustments. These parts are not available for consumer purchase and are only available for purchase by Cervélo retailers. Cervélo strongly recommends that all assembly and adjustment procedures be performed by an authorized Cervélo retailer.

NOTE: All non-proprietary components are available from your local distributor.

NOTE: This manual was developed to compliment the Cervélo General User Manual, and is intended as a supplement to the assembly and installation instructions supplied by the component manufacturers (provided with this bicycle).

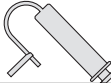
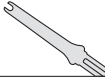
Tools	
	Bicycle workstand (types which secure bike by the seatpost, or pro-type stand with fork mount)
	Torque wrench(es) with 2.5Nm to 15Nm range and adaptors:
	Allen (Hex) head inserts: 2mm, 2.5mm, 3mm, 4mm, 5mm, 6mm, 8mm, 10mm
	Open ended wrenches: 7mm, 8mm, 10mm, 17mm
	Cable cutters
	Pliers

Tools	
	Phillips-head screwdriver
	Slot-head screwdriver
	Pedal wrench
	Brake rotor locking tools
	Hydraulic bleed kit
	Di2 wire tool – Shimano
	Good quality bicycle grease

P-SERIES ASSEMBLY OVERVIEW

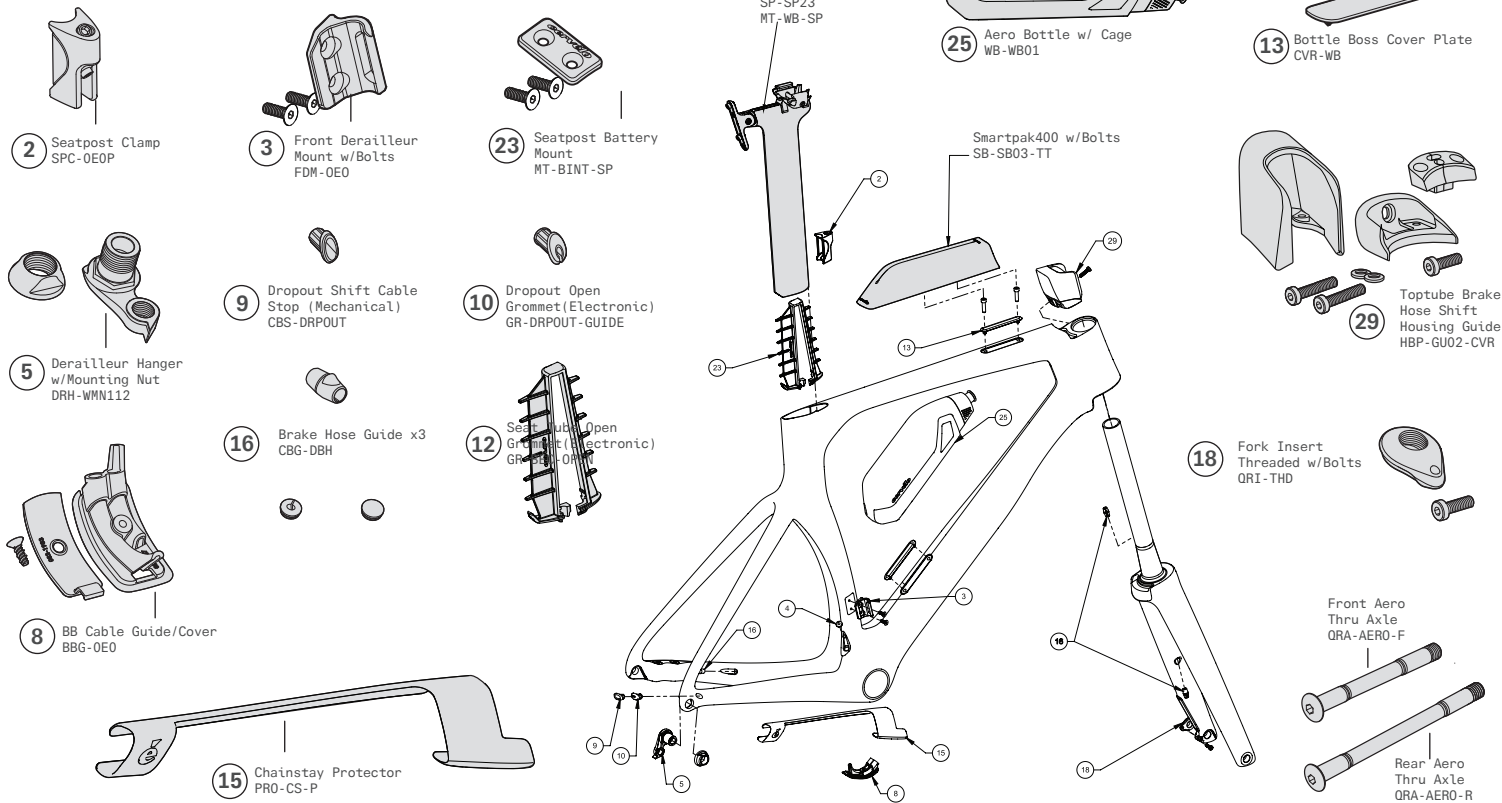

FRAME & FORK PREPARATION

1. Apply carbon assembly compound to both frame and seatpost.
2. Insert Seatpost Clamp (SPC-0E0P5) fully into frame so it is fully flush with the top tube.
3. Adjust height and torque to 8Nm maximum.

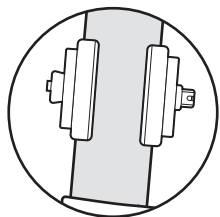
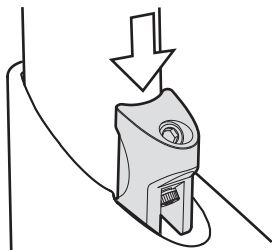

⚠ WARNING
Hold the frame using a secured seatpost only.

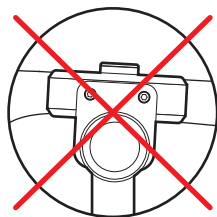

⚠ WARNING
Clamping the top tube can damage the frame and void your warranty.

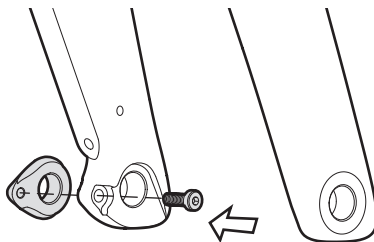

Lightly grease supplied M4 fixing screw, and install the Front Fork Axle Insert (QRI-THD) to the fork. Torque to 3Nm.

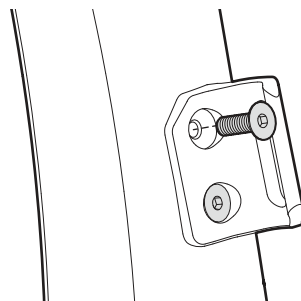

Ensure Front Derailleur Mount fixing screws are torqued to 3Nm.

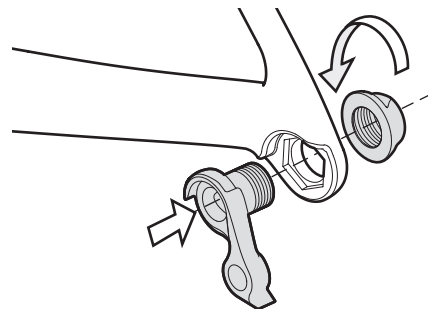

Lightly grease Rear Derailleur Hanger Fixing Nut and install Rear Derailleur Hanger (DRH-WMN112) finger tight. Final tightening will be done after rear wheel installation.

⚠ WARNING
Do not final tighten rear derailleur hanger assembly without rear wheel installed. Doing so will result in a misaligned derailleur and poor shifting.

FRAME & FORK PREPARATION

Note: Install GU02 Base piece onto frame prior to installing fork to ensure ease of access to the fixing screw.

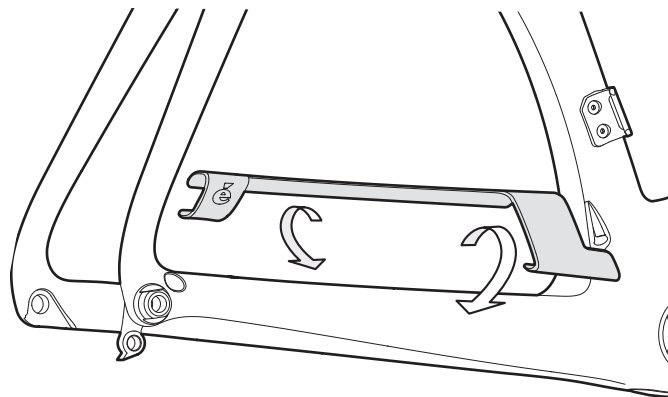
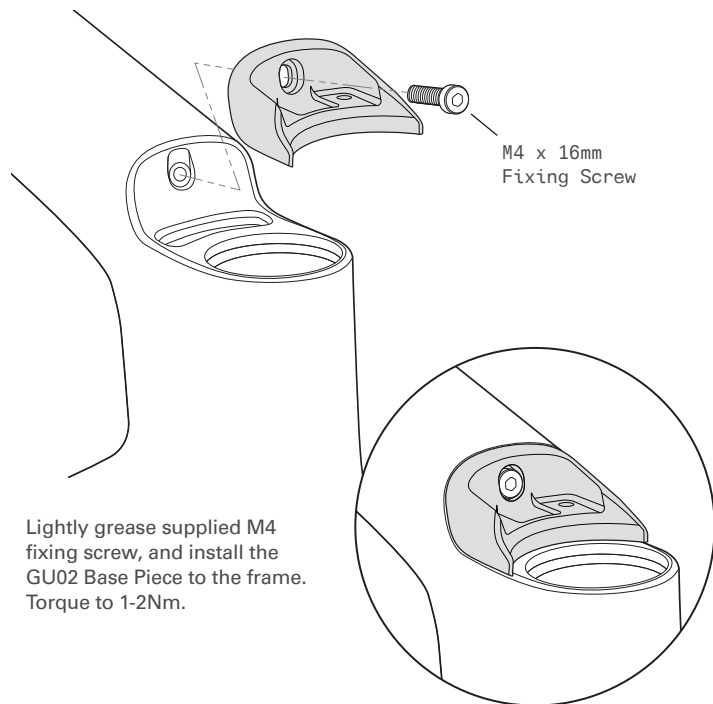

Clean the chainstay using isopropyl alcohol. Install the Chainstay Guard by removing adhesive backing, and fixing the guard to the frame. The bottom rearward edge should be approximately 15mm from the edge of the Rear Derailleur Hanger Fixing Nut.

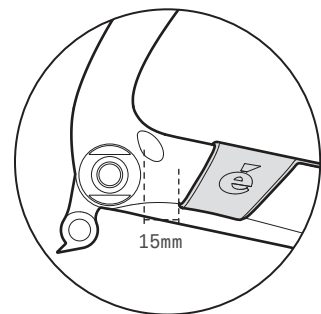

FORK INSTALLATION

1. Apply grease to the bearing seats, and install the upper & lower headset bearings into the head tube.
2. Fit the fork provided with your frame into the head tube with the complete headset, required spacers, and the stem.
3. Tighten the Top Cap bolt to take slop out of system and ensure the assembly is fully seated (1-2Nm). Mark the steerer tube at the top of the stem.
4. Remove fork and clearly mark the fork steerer tube at a point 4mm below the first mark. Take care to verify that this measurement is correct as this defines the cut line for the steerer tube.
5. Lightly grease supplied M4 fixing screws, and install the Fork Dual Offset Axle Inserts to the fork. Tighten to 3Nm.
 1. Maximum of 5Nm.
 2. As a final check ensure that the fork rotates freely in the head tube without any play or binding. If any problem is detected, loosen the bolts and perform steps 7) to 8) again.

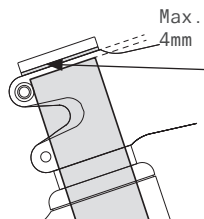
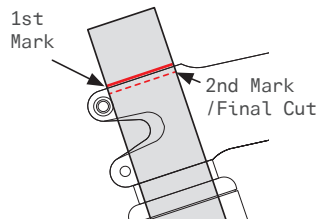

A 2.5mm spacer under the Stem Cap is advised

⚠ WARNING

Your Cervélo frame & fork have been designed to work together. Do not attempt to install an alternative fork.

⚠ WARNING

Avoid breathing the dust created during cutting carbon composite materials.

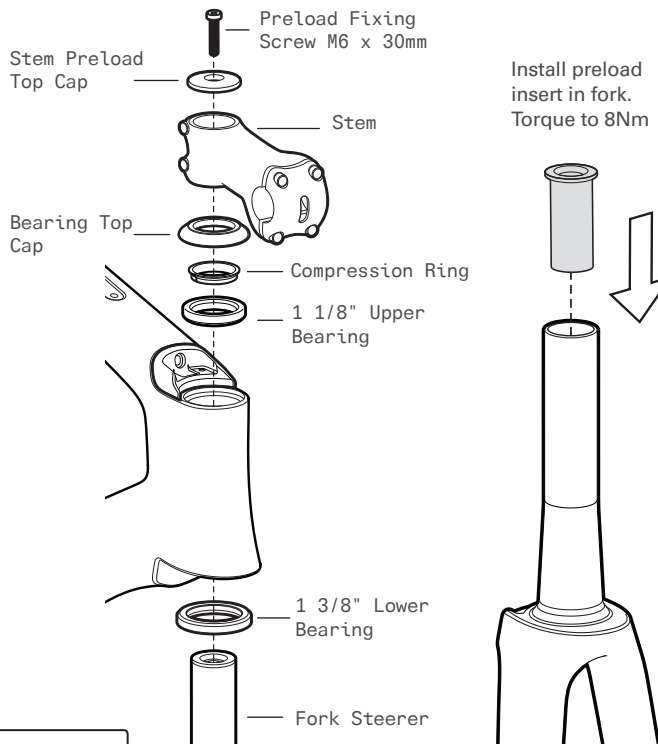

Install preload insert in fork.
Torque to 8Nm

NOTE: This diagram is for assembly reference only. During complete assembly, hoses and control cables will be present.

BRAKE HOUSING ROUTING

It is recommended that the rear hydraulic brake hose or brake cable housing is installed first. These routing illustrations are intended as a supplement to the manufacturer's installation instructions only. For both hydraulic and mechanical disc brakes, please refer to the component manufacturer's service center or website for further information.

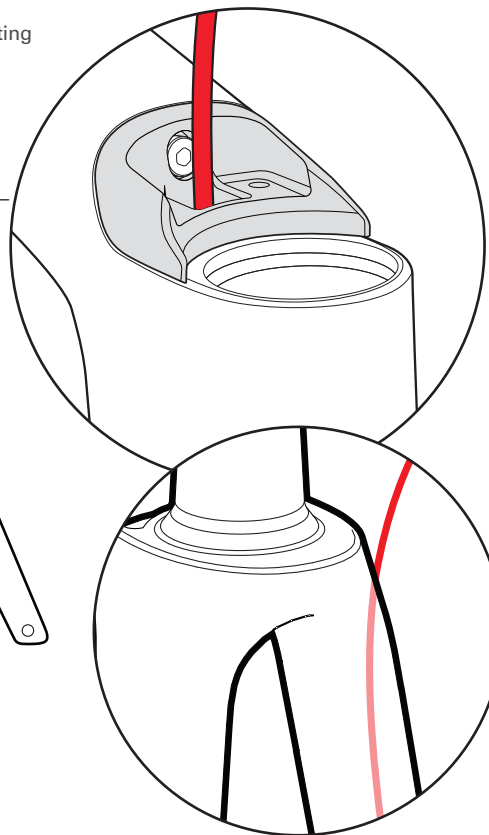
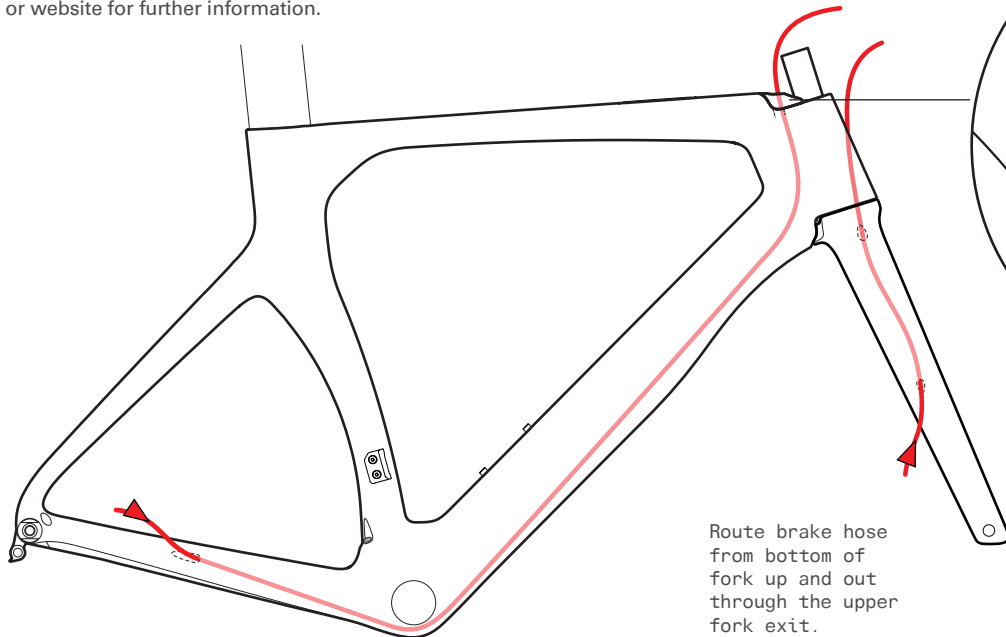

BRAKE HOUSING ROUTING

Route hydraulic brake hose or mechanical brake housing through the frame and fork with the Disc Hose Bushings (CBG-DBH). Install and adjust calipers as per manufacturer's instructions.

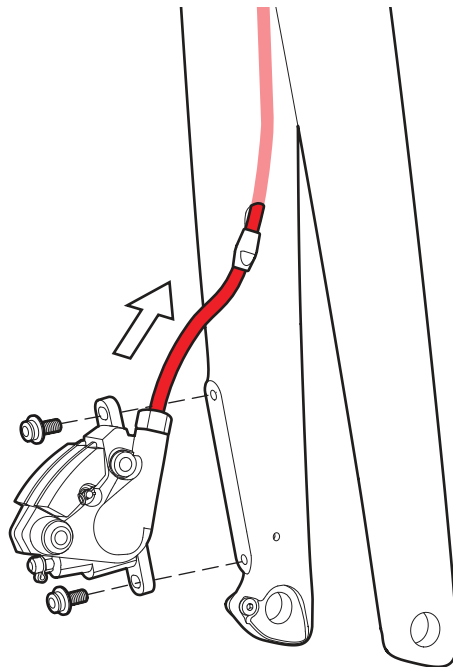
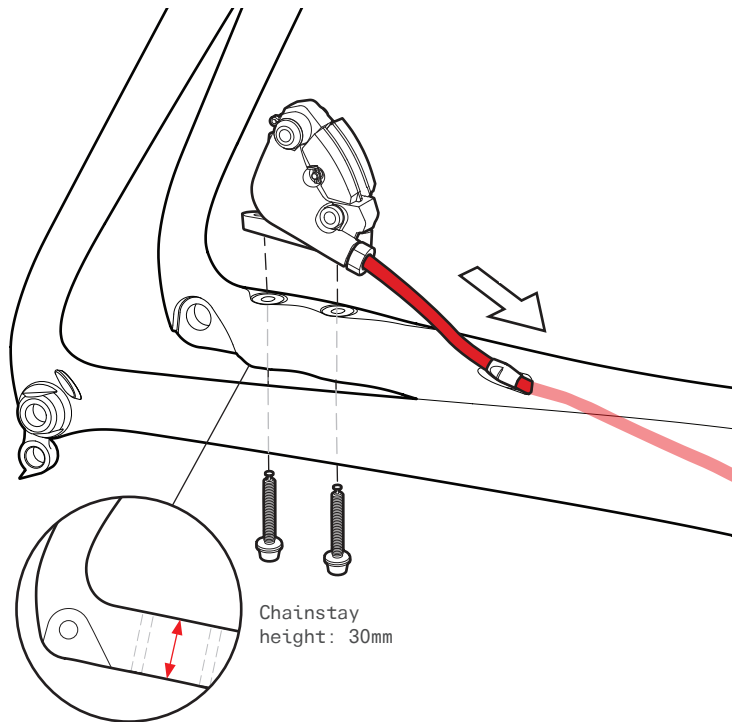

ELECTRIC CABLE ROUTING

It is recommended that electric cabling and junction points be installed after the brake hose has been installed. These routing illustrations are intended as a supplement to the manufacturer's installation instructions only. Please refer to the component manufacturer's service center or website for further information.

● Brake ● E-Wire

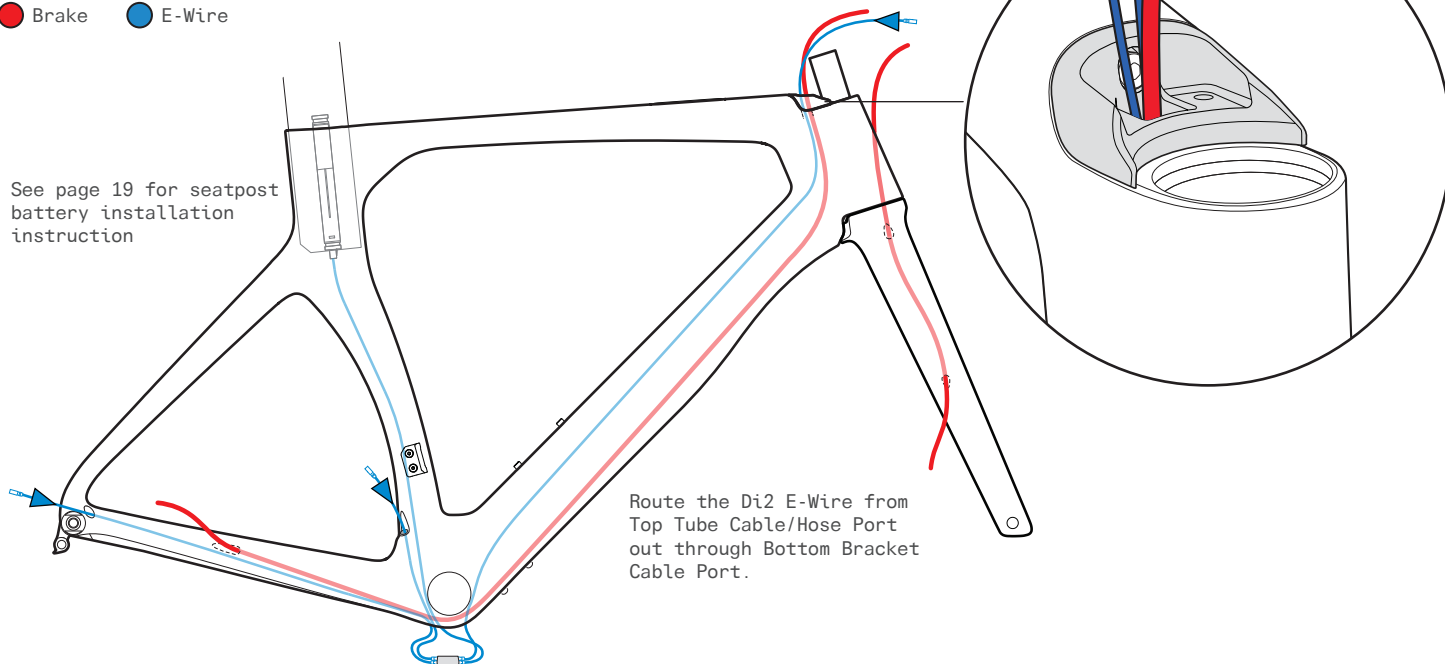

ELECTRIC CABLE INSTALLATION

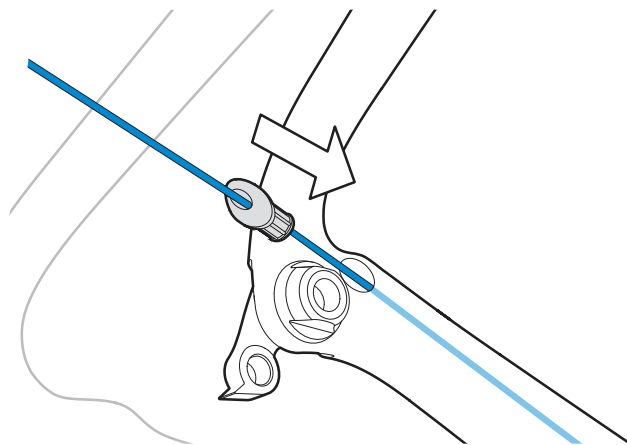
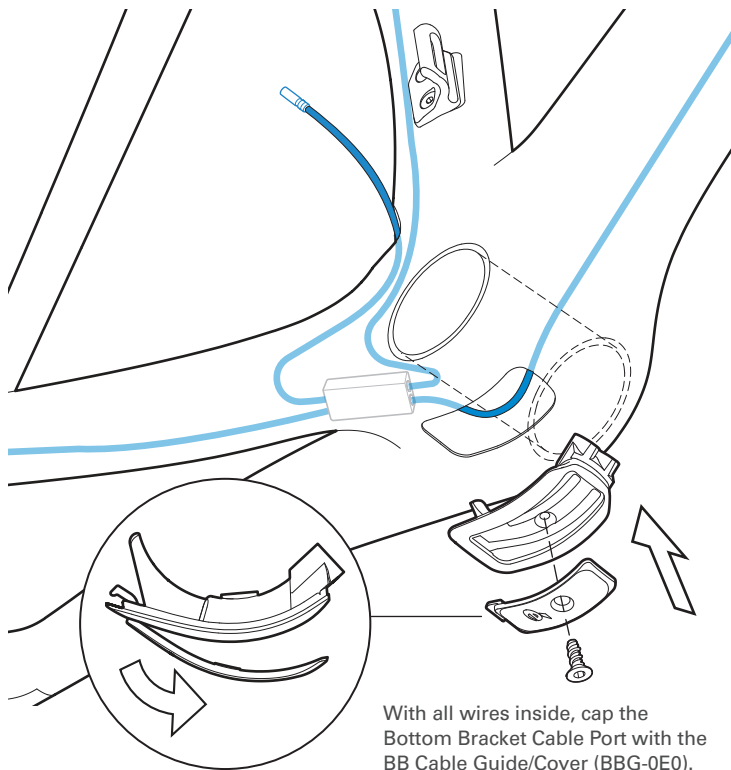

Install the Rear Derailleur Wire Guide (GR-DRPOUT-GUIDE).

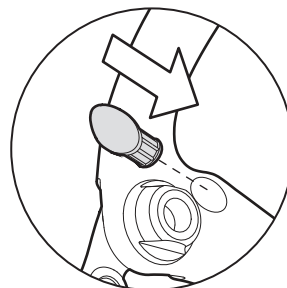

For wireless shifting systems install the Rear Derailleur Blanking Plug (GR-DRPOUT-CLOSED).

MECHANICAL CABLE ROUTING

It is recommended that front and rear derailleur cables be installed after the brake hose has been installed. These routing illustrations are intended as a supplement to the manufacturer's installation instructions only. Please refer to the component manufacturer's service center or website for further information.

● Brake ● Rear Shifter ● Front Shifter

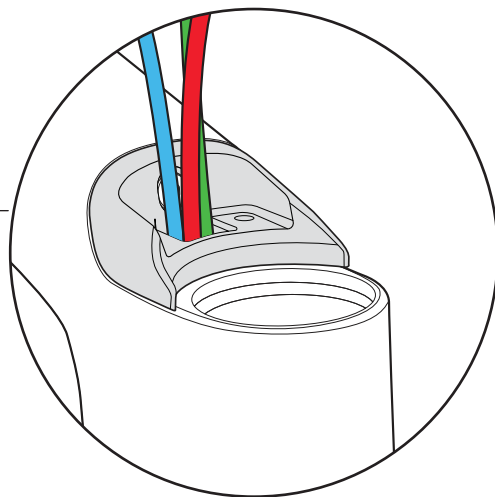
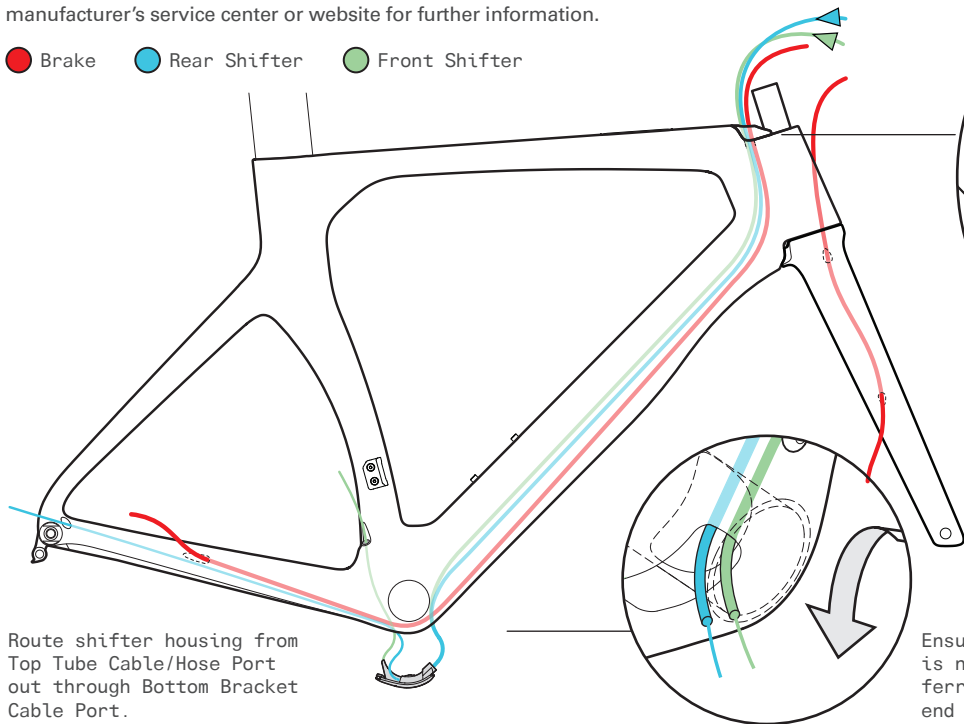

Route shifter housing from Top Tube Cable/Hose Port out through Bottom Bracket Cable Port.

Ensure that the shifter housing is not twisted together. Add ferrules to the bottom bracket end of the housing.

MECHANICAL CABLE INSTALLATION

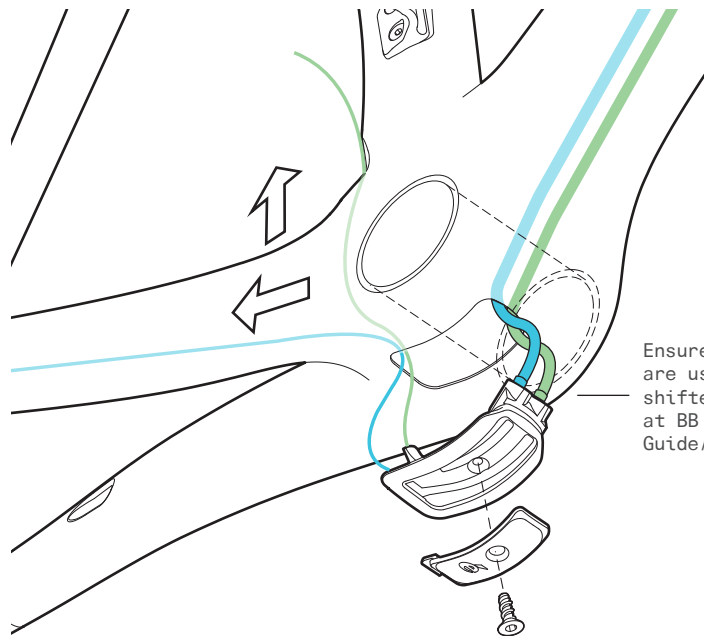

Ensure ferrules are used to cap shifter housing at BB Cable Guide/Cover.

The front cable travels across the non-drive side slot, and in the direction of the seat tube. The rear cable travels along the drive side slot, and along the chainstay. When complete, fix the BB Cable Guide/Cover (BBG-0E0) into place.

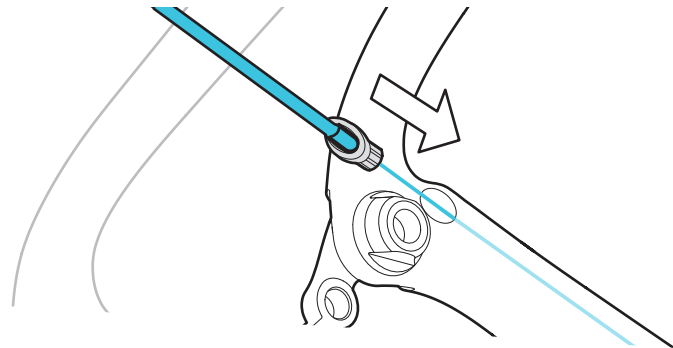

Install Rear Derailleur Press-In Cable Stop (CBS-DRPOUT).

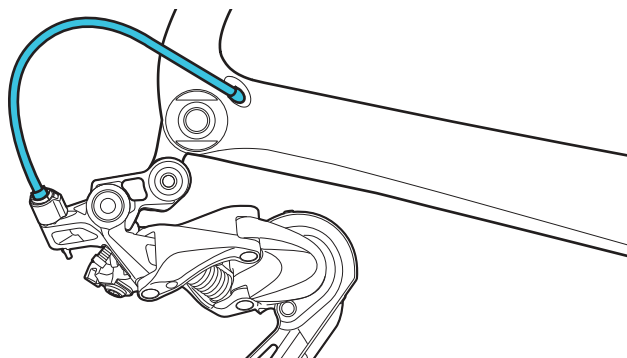

As per manufacturer's instructions, install rear derailleur on rear derailleur hanger, cut appropriate housing length, and attach cable.

TOP TUBE CABLE/HOSE GUIDE INSTALLATION

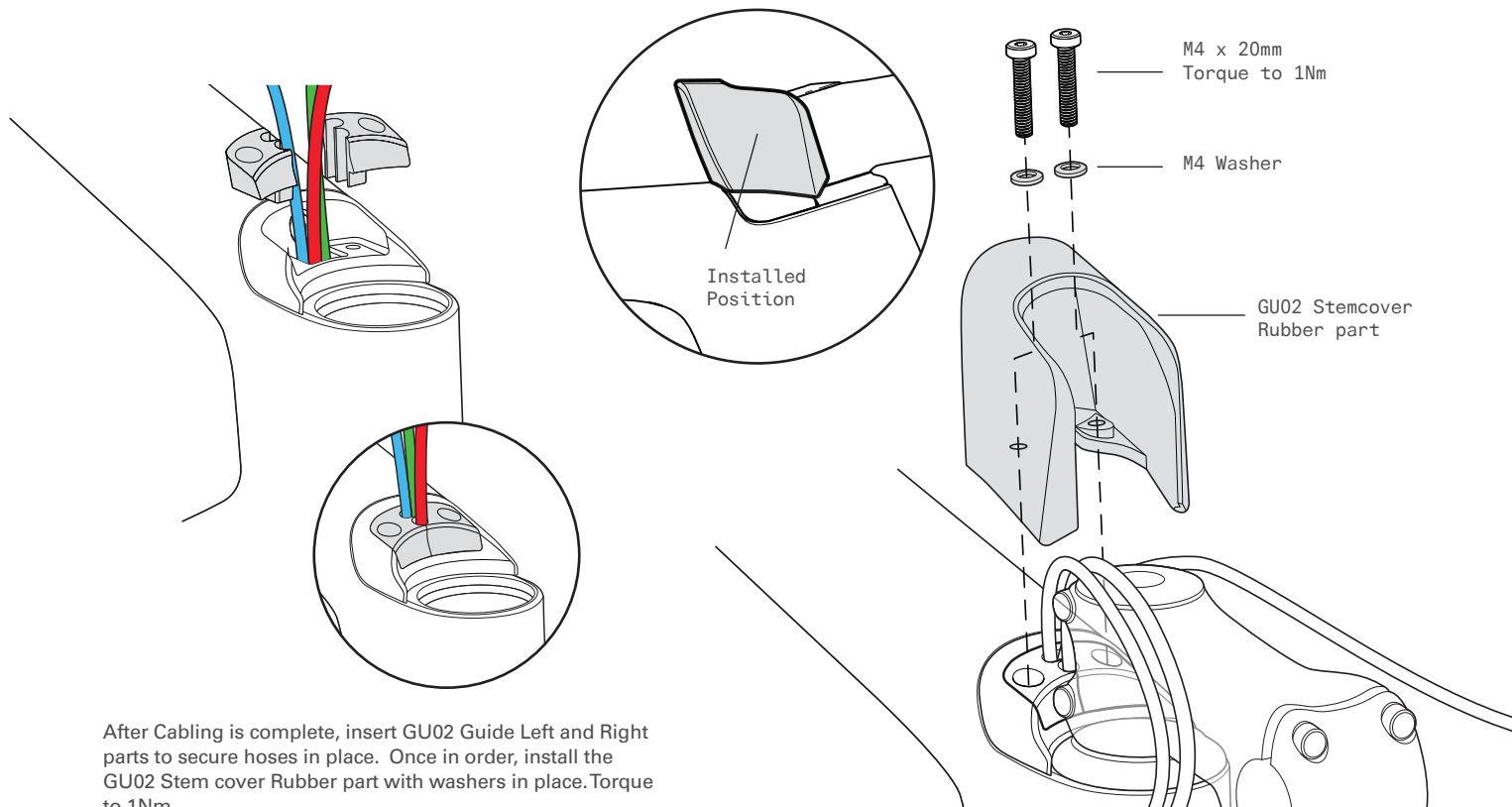

After Cabling is complete, insert GU02 Guide Left and Right parts to secure hoses in place. Once in order, install the GU02 Stem cover Rubber part with washers in place. Torque to 1Nm.

TOP TUBE SMARTPAK INSTALLATION

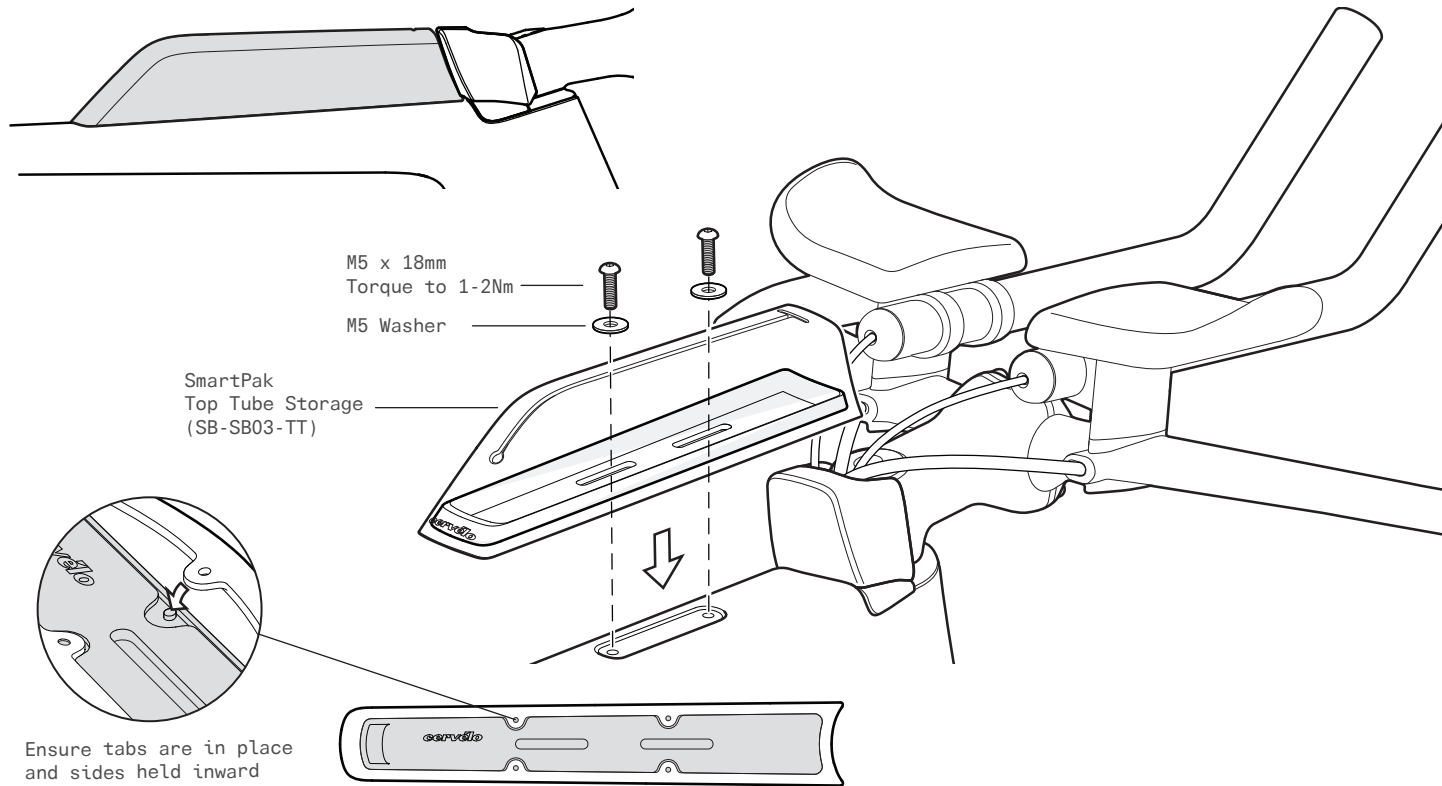

SEATPOST ASSEMBLY

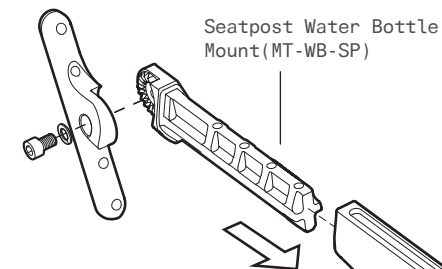

Slide the lightly greased seatpost bottle cage mount slug into the seatpost.

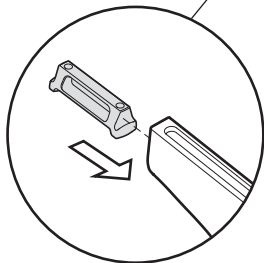

If not using the bottle cage mount, use the alternate seatpost slug (SPS-SP2123).

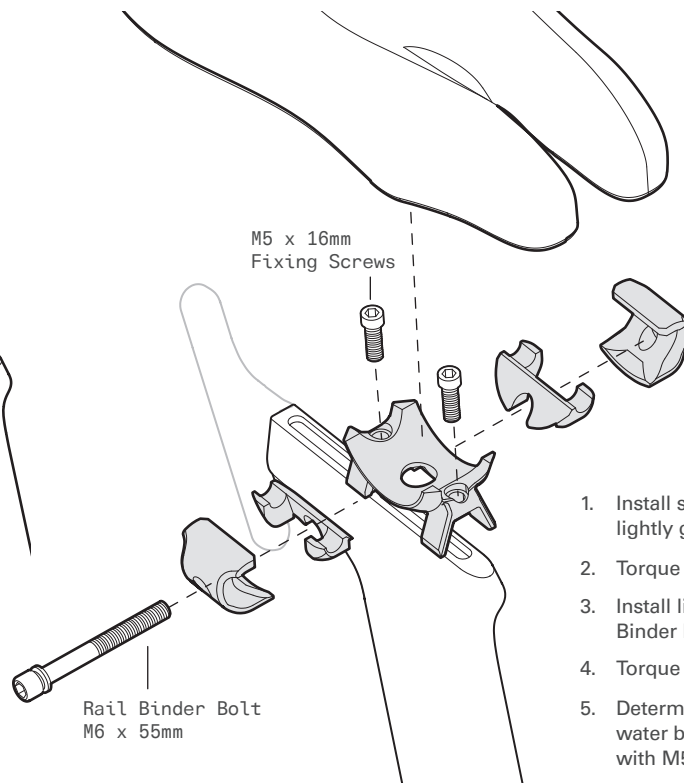

1. Install saddle mount to slug using lightly greased M5 fixing screws.
2. Torque to 6-7Nm.
3. Install lightly greased M6 Rail Binder Bolt, and install saddle.
4. Torque to 12Nm.
5. Determine desired angle, and attach water bottle mount to seatpost slug with M5 fixing screw.
6. Torque to 4Nm.

SEATPOST ASSEMBLY

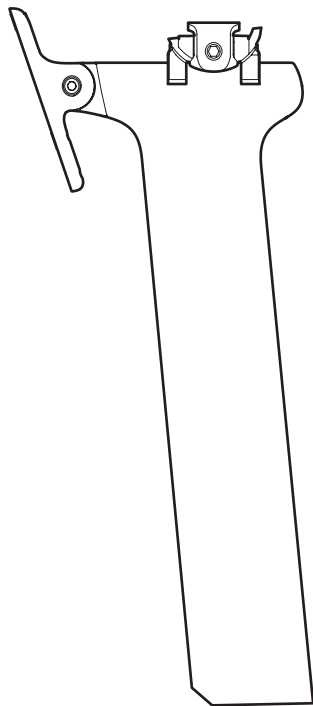

SP23 Seatpost
(SP-SP23)

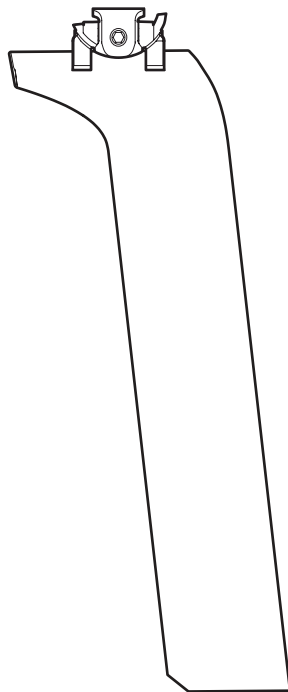

UCI P5 Seatpost
(SP-CER-UCI-ACB)

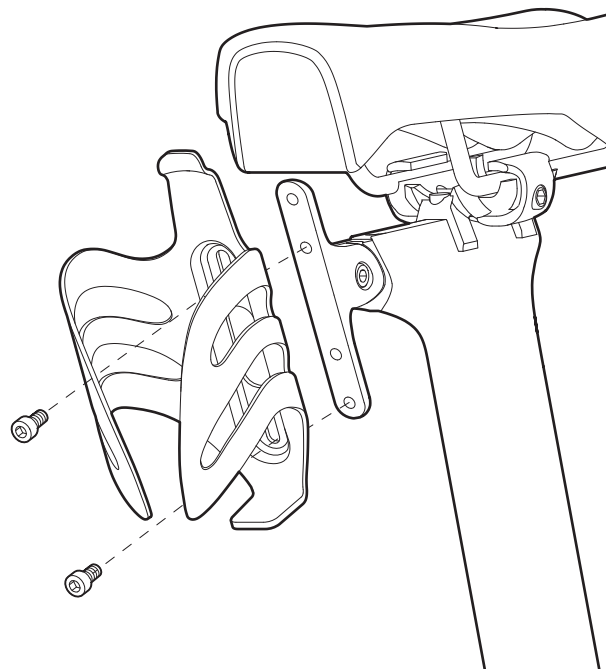

Attach water bottle cage using lightly greased
M5 x 8mm fixing screws. Torque to 2-3Nm.

SEATPOST CUTTING INSTRUCTIONS

Note: It is essential that all Cervélo Aero Seatposts, have a 45 degree chamfer cut on the rear trailing edge of the post. If trimming is required after fitting, the following method is recommended.

1. Taking care to maintain the minimum required seatpost insertion of 6.5cm and maximum of 8.5cm, carefully measure and use a light coloured grease pencil to accurately mark the cut-off location on the seatpost.
2. Insert the P Series Seatpost in the ParkTool SG-7.2 Saw Guide (or equivalent) so that the cut-off line can be seen clearly through the blade guide in the tool.
3. Using a blade designed specifically for cutting carbon composite materials (or a fine tooth blade with greater than 32 teeth per inch); proceed with cutting the Seatpost (as per ParkTool's instructions).
4. Use fine grit sandpaper to carefully remove any fraying or burring from the cut end. Reposition clamp approximately 10cm from the cut end.
5. With a grease pencil, mark a point 1cm from the cut end on the trailing edge of the Seatpost, and another 1cm from the back, on the bottom edge. Draw a line connecting them, forming a 45 degree guideline.
6. Placing the blade of your saw on the grease pencil mark, very carefully proceed to cut, resulting in a 45 degree chamfer being cut onto the trailing edge of the Seatpost.
7. Carefully sand the end and after applying carbon assembly compound, return to the frame.

WARNING

If trimming is required, final length should allow for a minimum 6.5cm of seatpost remaining in the frame. Failure to meet this requirement, may result in damage to the frame not covered by warranty policy, or serious injury to rider.

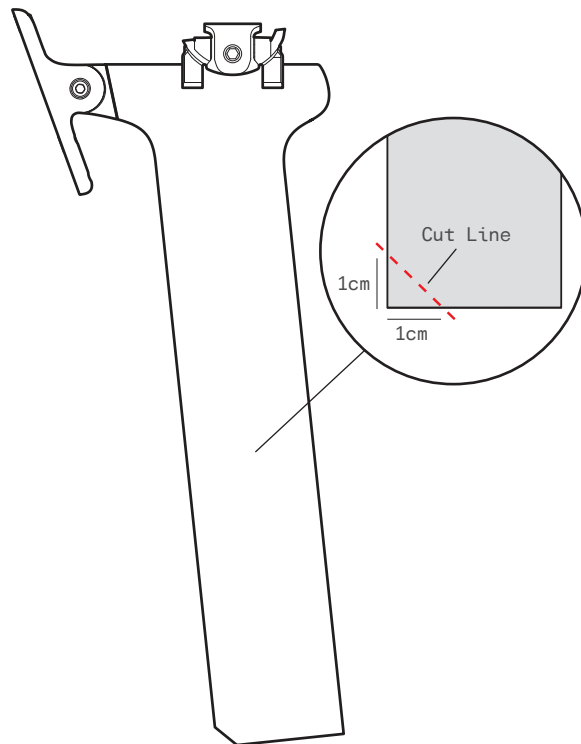

SEATPOST DI2 BATTERY INSTALLATION

Press the Di2 battery into the Seatpost Battery Mount (MT-BINT-SP) and attach the E-Wire according to the manufacturers instructions.

Insert the assembled battery and battery mount into the seatpost.

P Series Seatpost
Battery Mount
(MT-BINT-SP)

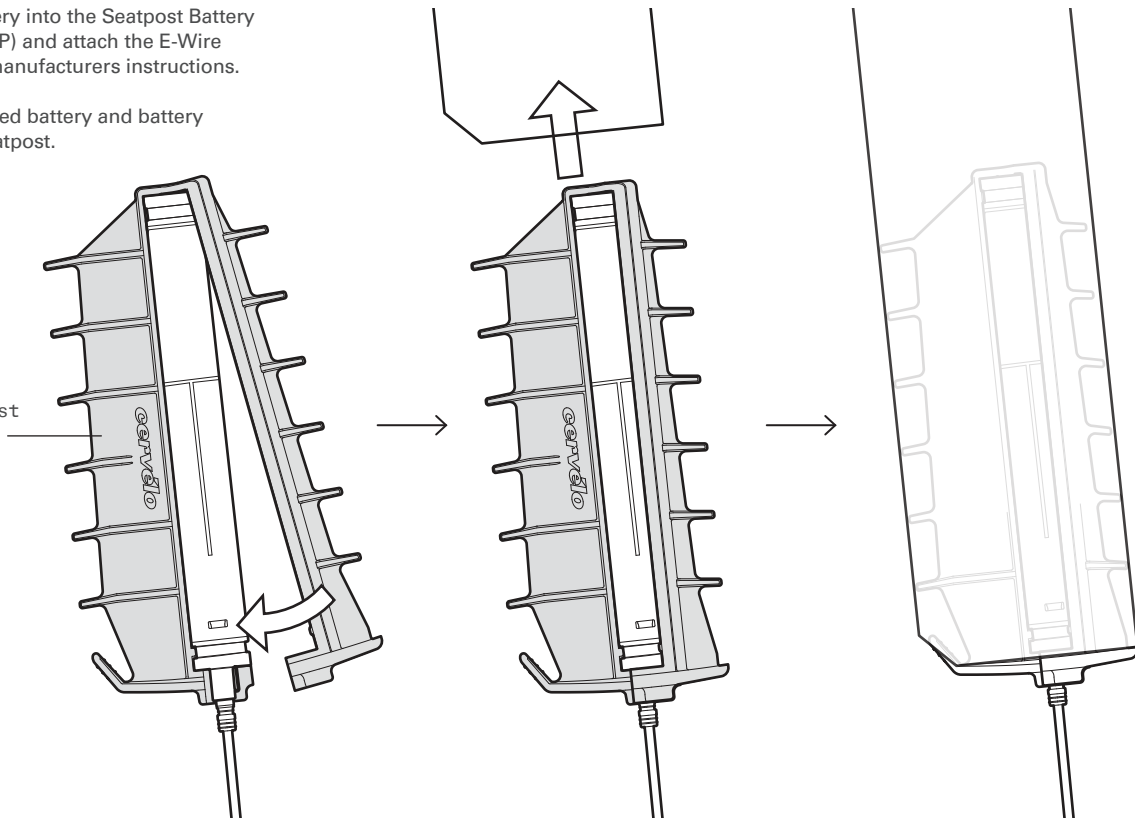

TIRE CLEARANCE

Your Cervélo bicycle complies with the ISO 4210-2:4.10.2 standard for tire clearance. In order to comply with these safety standards and maintain your Limited Lifetime Warranty, a minimum of 4mm of clearance must remain between the tire and any frame element. Due to the growing complexity of tire and rim interfaces, Cervélo recommends identifying the available space before choosing a tire.

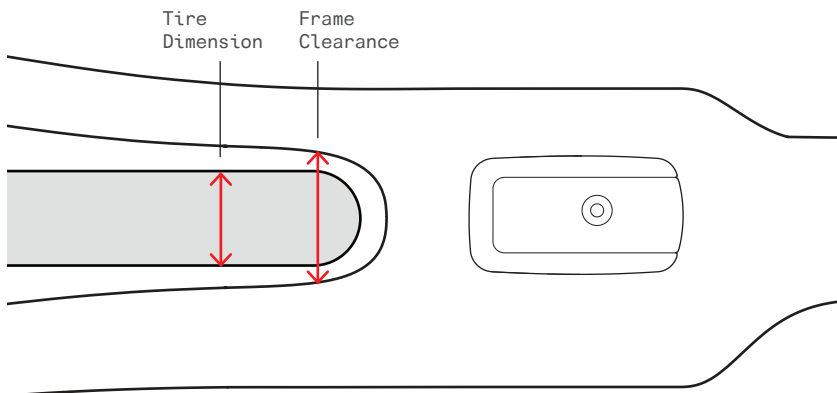

1. Measure the space between the chainstays at the bottom bracket junction.
2. Measure the space between the seatstays at the top of the tire.
3. Using the smallest of those two numbers, subtract 8mm (4mm per side) to determine the remaining space.
4. With the tire installed and fully inflated on your wheel, measure the tire width to ensure that it fits.

⚠ WARNING

Contact between the tire and the frame or fork may result in a loss of control while riding and potentially serious injury. Failure to follow these guidelines may result in damage to the frame not covered by Cervélo Limited Lifetime Warranty.

AERO THROUGH-AXLE WHEEL INSTALLATION

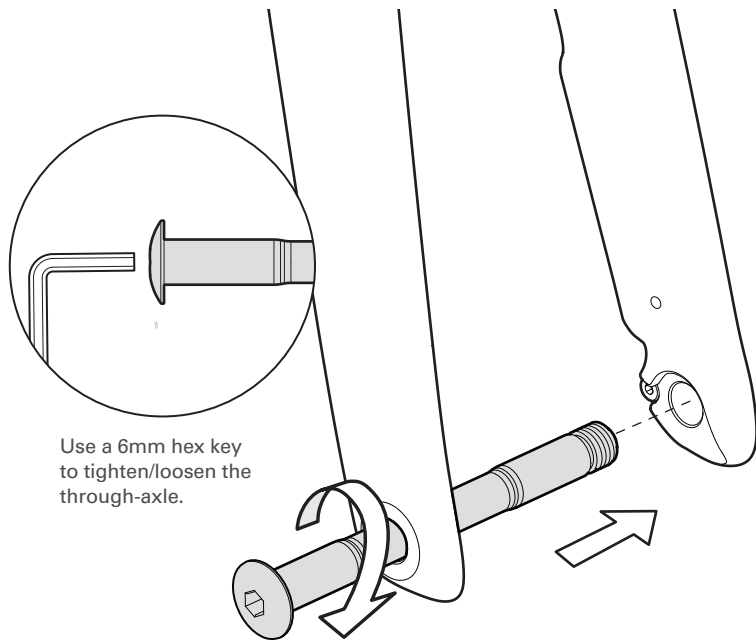

To secure the front wheel, install the greased axle, through the drive side drop out, through the wheel hub, and rotate to thread axle into opposite fork drop out until tight. Tighten to 12-15Nm.

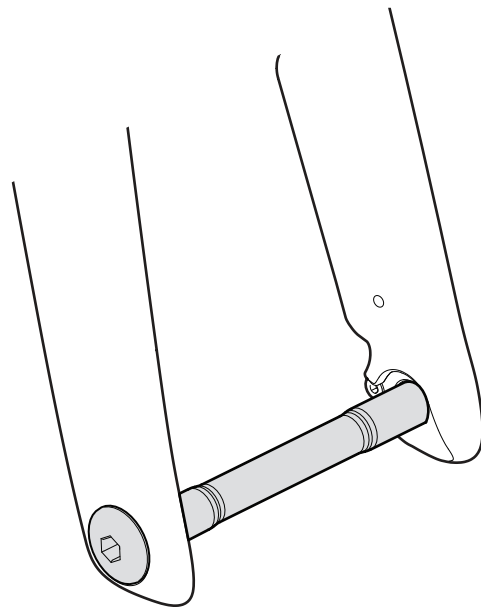

WARNING

To ensure rider safety, it is critical to install the Cervélo Aero Through-Axle correctly. Failure to do so may result in a crash, with potential for serious injury to the rider.

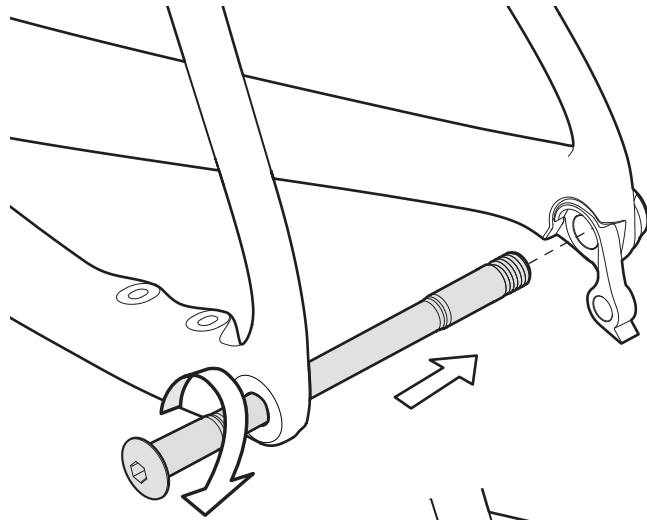

To secure the rear wheel, install the greased axle, through the non-drive side drop out, through the wheel hub, and rotate to thread axle into opposite fork drop out until tight. Tighten to 12-15Nm.

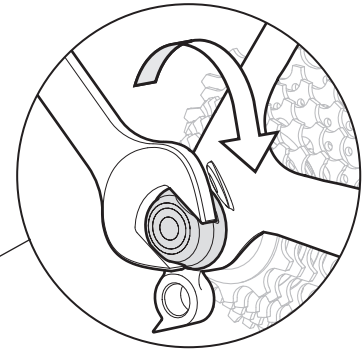
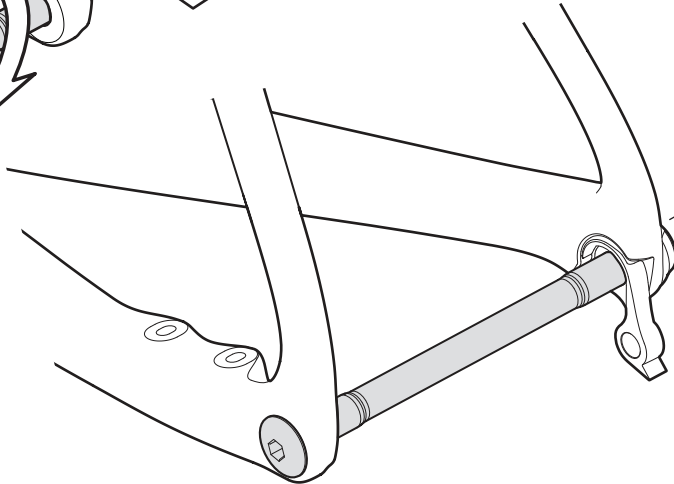

Perform final tightening on Rear Derailleur Hanger Fixing Nut using a 17mm wrench. This action is unique to initial assembly, and should not require adjustment afterwards.

⚠ WARNING
Adjust brakes as per manufacturer's instructions.

SMALL PART COMPATIBILITIES

Item Description	Cervélo Part No.	Compatible With/ Replaced By
Seat Tube Grommet For Di2 E-Wire	GR-ST-GUIDE/ GR-BEC-OPEN	GR-ST-CLOSED
Dropout Di2 Grommet	GR-DRPOUT-GUIDE	CBS-DRPOUT
Dropout Closed Grommet	GR-DRPOUT-CLOSED	CBS-DRPOUT
Chain Catcher Guide	CNC-ASY	FDM-OEO (Compatible)
Rear Derailleur Hanger Assembly- RAT	DRH-RAT	DRH-WMN112
Front Fork Axle Insert - RAT	QRI-RAT	QRI-THD
Aero Thru Axle (Front)	QRA-AERO-F	QRA-LVR-F
Aero Thru Axle (Rear)	QRA-AERO-R	QRA-LVR-R
UCI P5 Seatpost	SP-CER-UCI-ACB	SP-SP23

All small parts are available for purchase by Cervélo retailers. Please visit the Cervélo Customer Portal.

HARDWARE COMPATIBILITIES

Item Description	Specification
Compression Plug with Top Cap	FSA 1 1/8"- Ø23 (or equivalent)
Spacers	1 1/8" x 10mm/5mm/2mm
Bearing Cap	1 1/8" x 9mm (max height)
Split Ring	1 1/8"
Upper Bearing	1 1/8" 36x45
Lower Bearing	1 3/8" 36x45
Common Bottle Cage Bolt	M5x0.8 x 18mm SHCS

All hardware components can be purchased by any 3rd party, as long as they meet the above specification.

NOTE: All non-proprietary components such as those from Shimano or SRAM are available from your local distributor.

2020 P-SERIES RETAILER ASSEMBLY MANUAL

CER-PSERIES-V1.0 2019-06-07

www.cervelo.com

cervelo